



INSTRUCTION MANUAL

ANTENNA ELEMENT
AH-2b

Icom Inc.

FOREWORD

Thank you for your purchase of the Icom AH-2b ANTENNA ELEMENT for your vehicle. When used with the AH-3 or AH-2a HF AUTOMATIC ANTENNA TUNER the AH-2b allows mobile operation on all frequencies from 3.5MHz through 30MHz with the convenience of rapid, automatic tuning. The AH-2b may be installed easily to almost any kind of vehicle two hook, eliminating the need for drilling holes in the vehicle.

Please read this instruction manual carefully before installing your AH-2b. With proper care, the AH-2b will provide years of dependable and enjoyable mobile communication.

TABLE OF CONTENTS

SECTION	1	FEATURES	1
SECTION	2	MOUNTING METHOD	1
	2-1	ATTACHMENT TO A VERTICAL HOOK	1
	2-2	ATTACHMENT TO A HORIZONTAL HOOK.....	2
	2-3	ATTACHMENT TO AN ANGLED HOOK	2
SECTION	3	ANTENNA FEEDER CONNECTION.....	3
SECTION	4	MOUNTING THE ANTENNA ELEMENT.....	4
SECTION	5	AUTOMOBILE ROOF ANTENNA ELEMENT CATCH....	5
SECTION	6	OPERATION NOTES	5

Read SECTION 6 before operation.

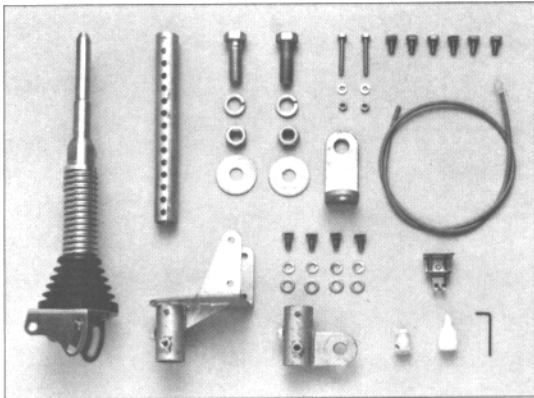

CONTENTS of AH-2b ANTENNA ELEMENT KIT

①	Antenna base	1
②	Antenna element-2.5 meters (not shown)	1
③	Shaft (A)	1
④	Antenna base bracket	1
⑤	Hex bolt (M16 x 50)	2
	(S-washers, nuts, flat washers included)	
⑥	Hex bolt (M6 x 50)	2
	(S-washers, nuts included)	
⑦	L angle bracket	1
⑧	Hex bolt (M8 x 15)	4
	(S-washer, flat washers included)	
⑨	Tow hook bracket	1
⑩	Hex bolt (M8 x 15)	6
⑪	Antenna feeder cable (90cm)	1
⑫	Antenna element catch	1
⑬	Cable lock	1
⑭	Waterproof cap	1
⑮	Allen key wrench	1

SECTION 1 FEATURES

■ HIGH QUALITY ANTENNA ELEMENT

The stainless steel antenna element has sufficient strength and flexibility for safe mobile operation even at high-speeds.

■ EASY INSTALLATION

Introducing a newly designed tow hook mounting bracket for the antenna, installation on all kinds of vehicles with various tow hook configurations is simple and fast.

All mounting hardware necessary for a complete installation is supplied, and metal parts are specially constructed to resist natural weathering effects.

SECTION 2 MOUNTING METHOD

2-1 ATTACHMENT TO A VERTICAL HOOK

- ① Attach the tow hook bracket to the automobile tow hook using a hex bolt, S-washer, flat washer and nut.
- ② Insert shaft (A) into the tow hook bracket and attach with a hex bolt, S-washer and nut. Tighten the 3 other hex bolts into the tow hook bracket.
- ③ Attach the antenna base to shaft (A) with hex bolts, S-washer and nut. Tighten all bolts.

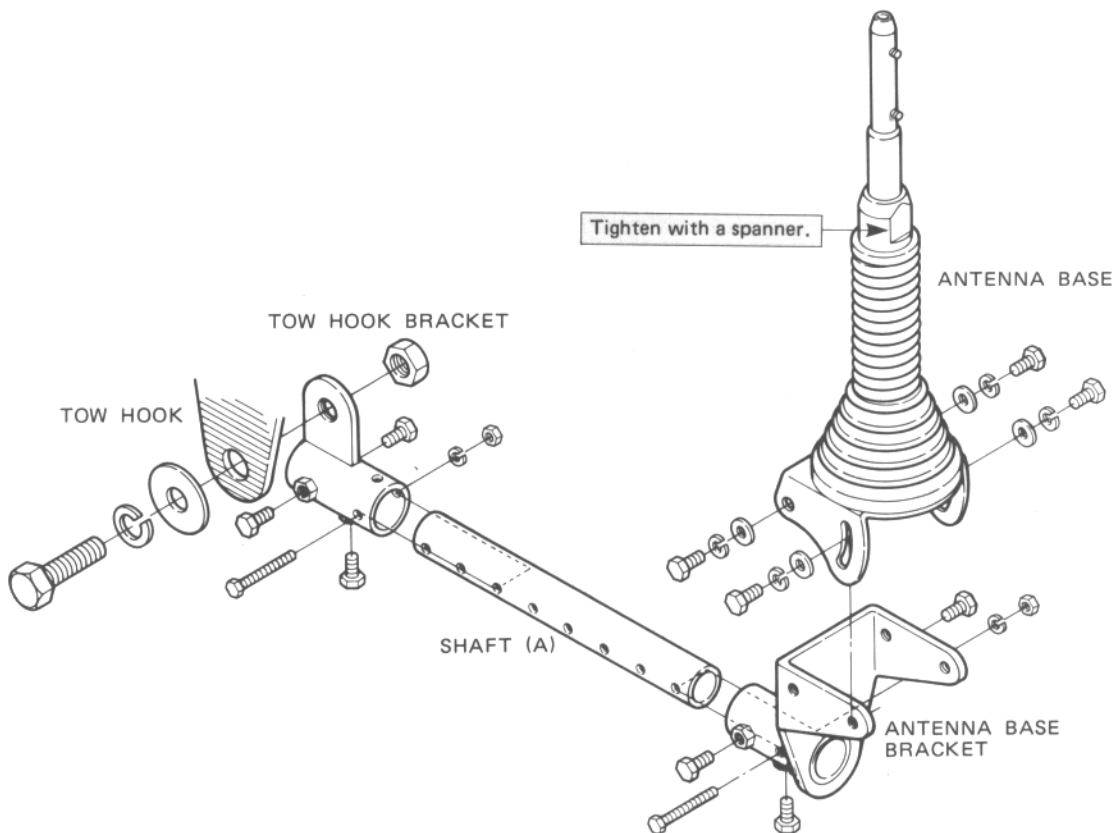

2-2 ATTACHMENT TO A HORIZONTAL HOOK

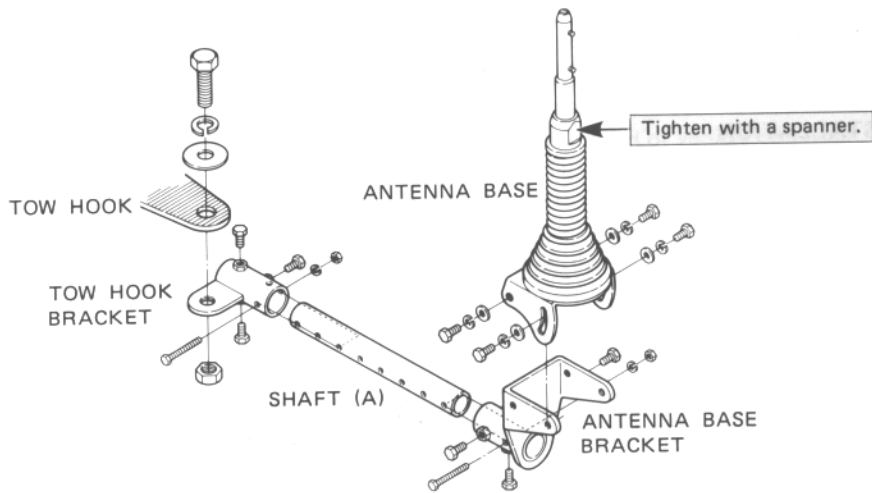

2-3 ATTACHMENT TO AN ANGLED HOOK

- ① Attach the L angle bracket to the automobile's tow hook with a hex bolt, flat washer, S-washer and nut. Tighten securely.
- ② Attach the tow hook bracket to the L angle bracket with a hex bolt, S-washer and nut. Tighten.
- ③ Follow steps ② and ③ under ATTACHMENT TO A VERTICAL HOOK.

NOTE: Use a spanner and a box wrench when tightening the nuts and bolts to prevent shifting of the antenna. Periodically check that the hardware is still tight.

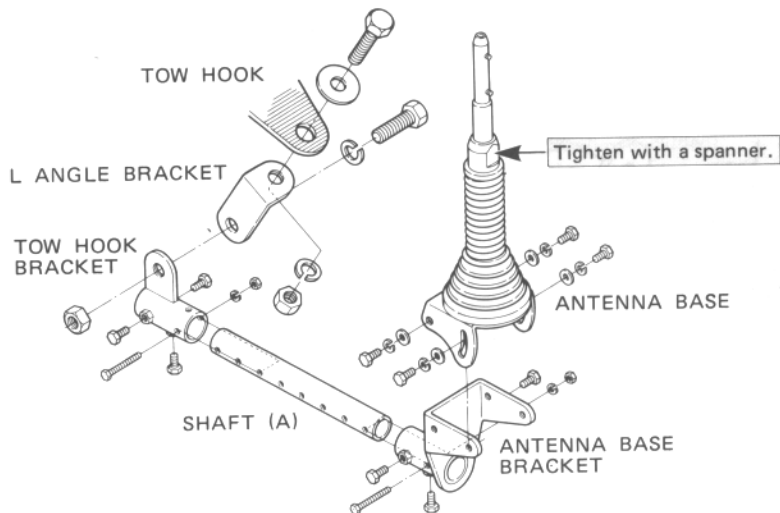

SECTION 3 ANTENNA FEEDER CONNECTION

The AH-2b works best when used with the Icom AH-3 or AH-2a antenna tuner. When using the AH-2b together with the AH-3 or AH-2a, no tuning is necessary since this operation is performed automatically by the AH-3 or AH-2a.

The following explains the AH-2b and AH-2a or AH-3 connection.

■ TUNER UNIT to ANTENNA BASE

- ① Run the cable between the tuner unit and the antenna base using the waterproof cap and cable lock as shown in the diagram. The cable is 90 centimeters long and may be cut if necessary, but its length should be 50 centimeters or longer.

Avoid running the cable against or near the muffler or sharp metal parts outside the trunk.

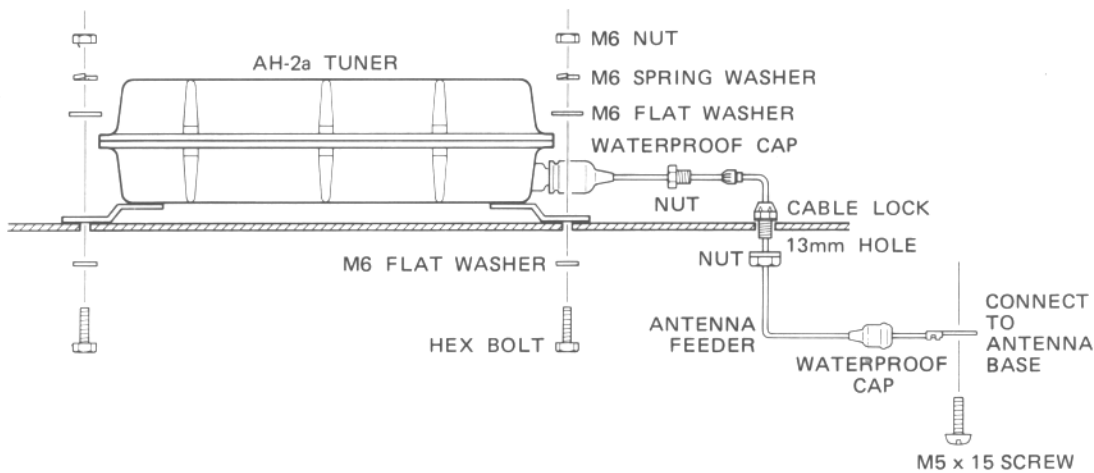

- ② Connect the end of the cable to the antenna base as shown in the diagram.

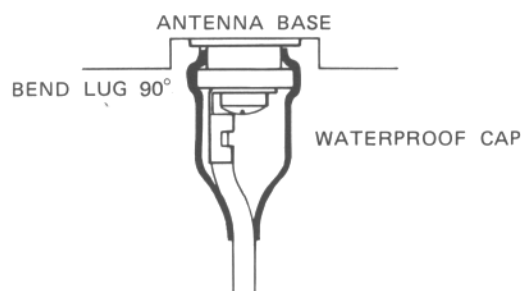

- ③ Prevent the cable from hanging loosely under the chassis by pulling excess slack into the trunk and tightening the cable lock.

Remember, the VSWR may be affected adversely if this feeder cable changes position or rubs against other objects.

SECTION 4 MOUNTING THE ANTENNA ELEMENT

- ① Insert the antenna element into the hole at the top of the antenna base. The element should enter the base as deep as 13 to 14 centimeters. Loosen the set screws further, if necessary, for proper element insertion.

NOTE: The antenna element holder is loosely screwed into the antenna base spring at the factory. Be certain to tighten this joint with a spanner during assembly.

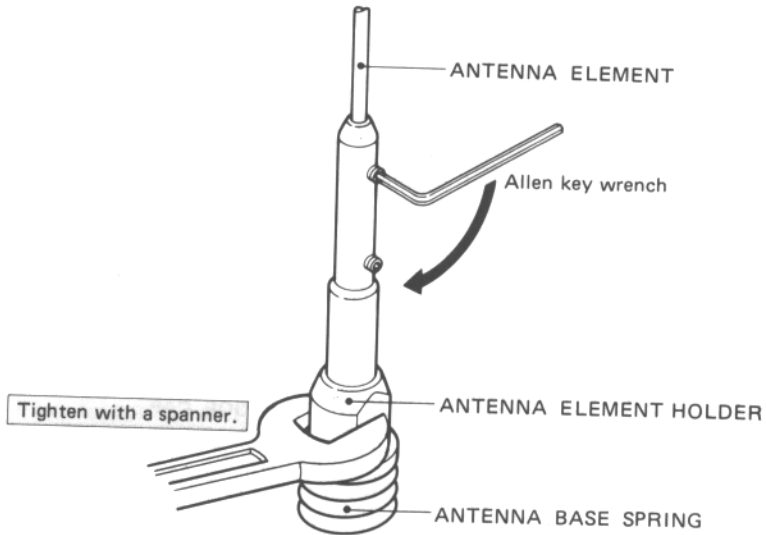

- ② Loosen the 4 hex bolts on bracket B and orient the element in a vertical position. Tighten the hex bolts.

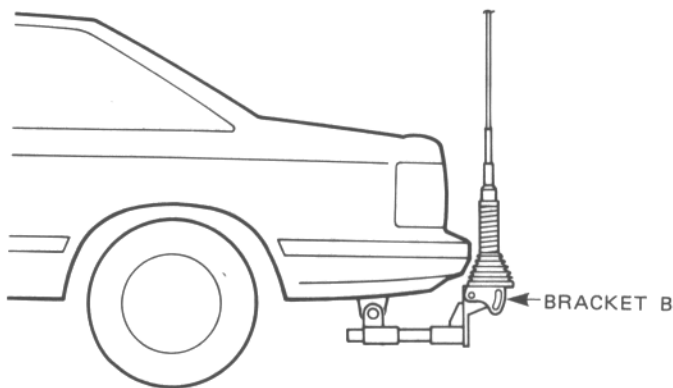

SECTION 5 AUTOMOBILE ROOF ANTENNA ELEMENT CATCH

The purpose of the antenna element catch is to hold the antenna tip to allow easy parking, in a garage for example, or passage under overhead obstructions with little clearance.

- ① Attach the antenna element catch to the automobile roof rain-gutter as shown in the diagram. Use the accessory allen key wrench to mount the catch.

ANTENNA ELEMENT CATCH

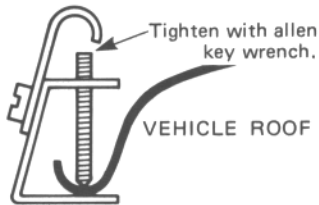

ANTENNA ELEMENT

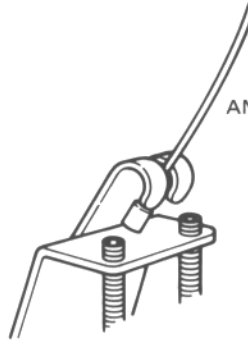

NOTE: PREVENT ELECTRICAL SHOCKS. Do not install or operate your AH-2 system at a location where the antenna element may be touched. High voltages are present.

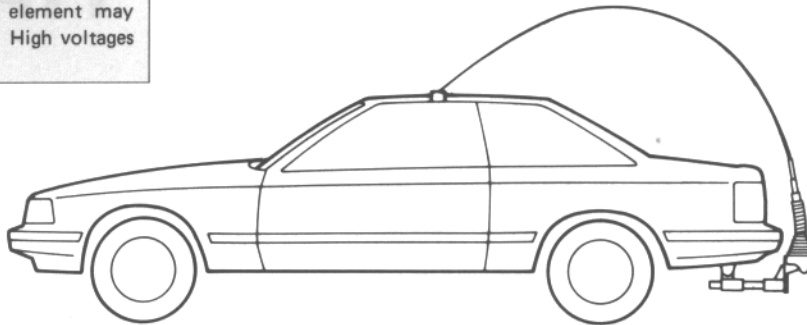

SECTION 6 OPERATION NOTES

- (1) DO NOT operate mobile from a location where the antenna element may be easily touched. High voltage is present.
- (2) DO NOT install the tuner unit where any antenna connections can be touched in a base station environment.
- (3) When operating from a moving vehicle, take care the antenna element does not interfere with other vehicles on the road.